

FRONT VIEW

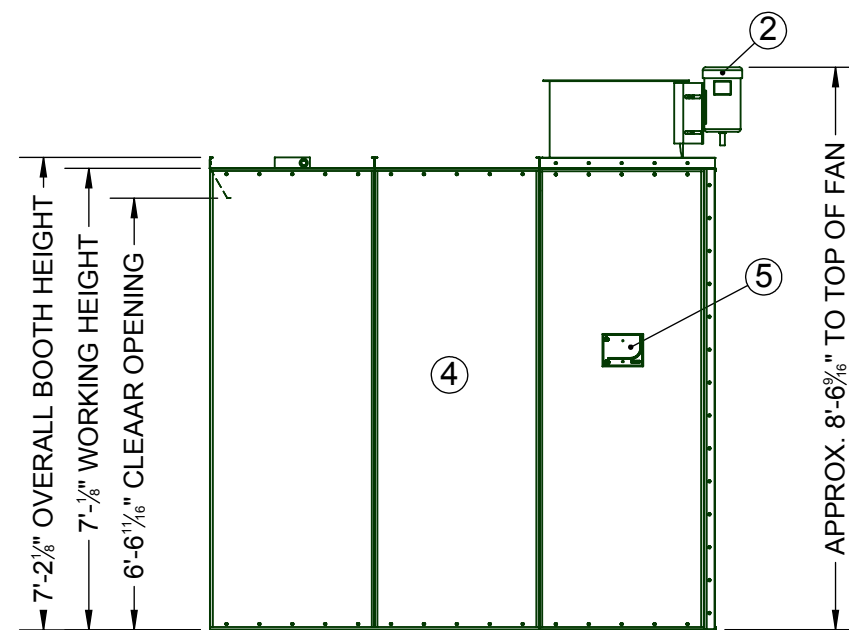

SIDE ELEVATION

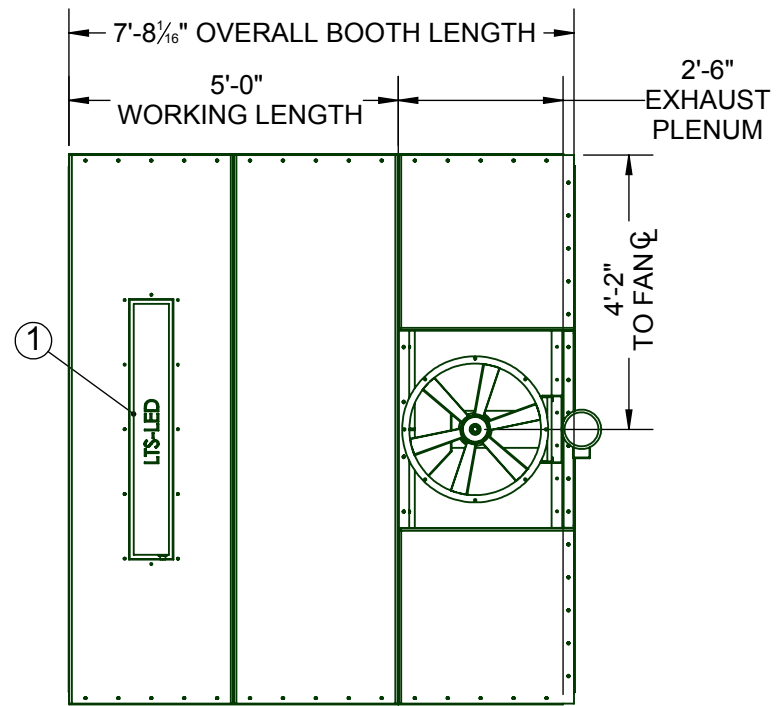

PLAN VIEW

ITEM	QTY.	Description
1	1	LTS LED LIGHT FIXTURE;4000 Lm OUTPUT ETL LISTED CLASS1 DIVISION2,INSIDE ACCESS.
2	1	24Ø TUBEAXIAL FAN; RATED FOR 7,150 SCFM EXHAUST @ 1/2 SP; DRIVEN BY 2 HP ODP TYPE MOTOR
3	1 LOT	EXHAUST ROLL FILTER W/ ASSOCIATED HARDWARE & TOOLS
4	1 LOT	18 GA GALVANIZED STEEL SHELL
5	1	MANOMETER
6	1	1/2" AIR SOLENOID VALVE (NOT SHOWN)

IB-08-07-05-00-S

